

**DETAIL OF FENCING FASTENING & BRACING**

NTS

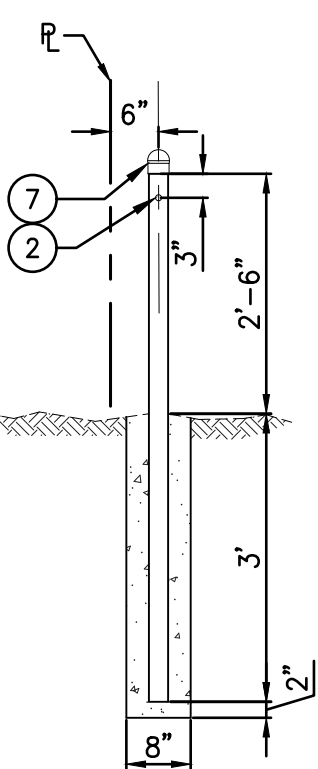

**TYPICAL SECTION**

NTS

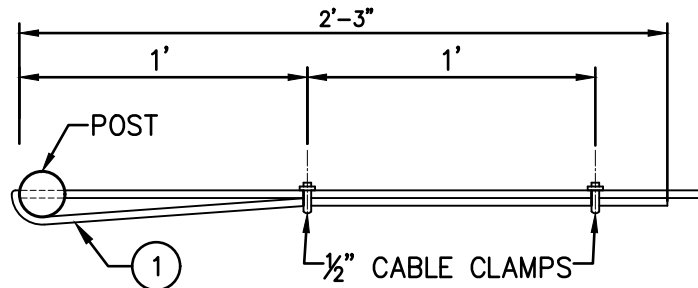

**CABLE FASTENER DETAIL**

NTS

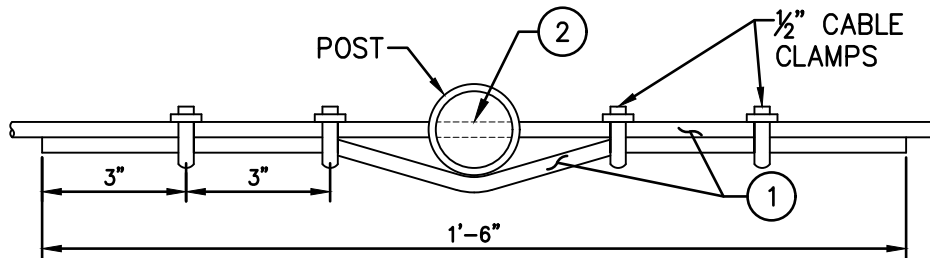

**SECTION A-A**

(PIGTAIL)  
(TYPICAL EVERY FOURTH POST)

NTS

**KEYED NOTES:**

1. 1/2" DIAMETER CABLE.
2. 3/4" DIAMETER HOLES FOR CABLE THRU CENTER OF POST. PROVIDE ADEQUATE TENSION IN THE CABLE TO MINIMIZE SAG BETWEEN SPANS.
3. LINE POST 2 3/8" O.D.
4. GATE, END AND CORNER POST 2 3/8" O.D.
5. DIAGONAL BRACE AT EVERY ANGLE POINT AND IN END SPANS 2 3/8" O.D. WELDED IN PLACE.
6. 2000 PSI (4 SACK CONC.) AT EVERY 4TH POST, EVERY ANGLE POINT, BRACE POINT AND AT ENDS.
7. CAPS ON ALL POSTS.
8. BOLT ASAE S276.4 REFLECTIVE SIGN TO CABLE, TACK WELD NUT TO THREADS, EVERY OTHER SPAN.

**GENERAL NOTES:**

- THERE SHOULD BE ENOUGH TENSION IN THE CABLE TO MINIMIZE SAG BETWEEN SPANS.



Southern Sandoval County  
Arroyo Flood Control Authority

STANDARD DRAWING  
M104  
CABLE FENCE