

**Harvey Jones Channel River Outlet
SSCAFCA IFB #: 2021-04**

ADDENDUM #1 (September 17, 2021)

Addendum #1 provides answers to questions that were asked during the pre-bid conference and/or submitted by potential bidders for this project. Addendum #1 also provides an updated Sheets 1 and 9 of the plan set.

Attachments:

Sheet 1 Cover Sheet – (Change: Adding sheets with final signatures)

Sheet 9 Typical Sections – (Change: modifications to Section C-C and new Section D-D)

Questions asked during the pre-bid meeting:

Q1: Are there Federal wage rates associated with this project?

A1: No. This is a locally funded public works project so there is a state wage rate decision included in the bidding manual that will apply for this project.

Q2: Is there a staging area in the project area?

A2: Yes, there is a staging area immediately west of the project area that will be made available to the successful contractor.

Q3: When do you anticipate Notice to Proceed will be issued?

A3: We are anticipating Board of Directors approval on September 23. After that, we will enter into a contract with the successful low bidder. We are anticipating NTP in mid to late October.

Q4: Are there outage time restrictions for bypass pumping? Is the design engineer comfortable with the required bypass pumping rate?

A4: No, there are no time restrictions for bypass pumping. Yes, the design engineer is comfortable with the specified flow rates and equipment specified.

Q5: How much time will be required for cure for the grout used in the effluent line part of the project.

A5: Depends on what grout material is submitted by the contractor. Engineer has seen grout submittals where cure time is measured in minutes.

Q6: What is the dimension ratio of the existing polyethylene sewer effluent line that will be cut?

A6: The existing line is DR 17.

Q7: What is the anticipated maximum flow?

A7: The anticipated maximum flow is 12 MGD with a maximum velocity of 11 fps in the temporary 20-inch bypass line.

Q8: Will the Owner be flexible on the discharge location for the bypass pumping operation?

A8: Yes, the Owner will work with the contractor on proposals for where to discharge bypass pumping.

END OF ADDENDUM

SOUTHERN SANDOVAL COUNTY ARROYO FLOOD CONTROL AUTHORITY

HARVEY JONES CHANNEL RIVER OUTFALL

SSCAFCA Project No. MO_P0040-01 MONTOYAS ARROYO WATERSHED



Southern Sandoval
County
Arroyo Flood Control
Authority
1041 Commercial Dr. S.E.
Rio Rancho, New Mexico 87124
505-892-RAIN (7246)
505-892-7241 (Fax)
www.sscafca.com



VICINITY MAP

SHEET INDEX	
SHEET NO.	SHEET TITLE
1	COVER SHEET
2	GENERAL NOTES
3	SURVEY SHEET 1
4	SURVEY SHEET 2
5	SURVEY SHEET 3
6	SITE LAYOUT PLAN
7	GENERAL GRADING PLAN
8	GENERAL DETAILS
9	TYPICAL SECTIONS
S-1	ADDITIONAL GENERAL NOTES
S-2	PLAN AND SECTIONS
S-3	PLAN AND SECTIONS
S-4	DETAILS
U-1	PLAN
U-2	DETAILS

HARVEY JONES CHANNEL
RIVER OUTFALL

COVER SHEET

APPROVALS

SSCAFCA: Charles Thomas DATE: _____
0-616 signed by Char & Thomas
 DN on Charles Thomas @ SCAFCA
 Title: Executive Engineer
 email: thomas@sscafca.com, c. US
 Date: 7/20/2019 09:27:55 -0600
 EXECUTIVE ENGINEER

CITY OF RIO RANCHO: [Signature] DATE: 9/8/21
 UTILITY DEPARTMENT

MIDDLE RIO GRANDE CONSERVANCY DISTRICT: [Signature] DATE: 9/13/2021
 CHIEF ENGINEER

REVISIONS & CHANGE NOTICES		
MARK	DESCRIPTION	DATE

PROJECT NO: MO_P0040-01
 DESIGNED BY: DG
 DRAWN BY: KLF
 CHECKED BY: AE
 DATE: 9/3/2021

1

SHEET 1 OF 9

Notice of Extended Payment Provision
 This contract allows the owner to make payment within 45 days after submission of an undisputed request for payment.

Plotted: September 14, 2021 10:13:52 AM
 C:\Users\charles.thomas\OneDrive\Documents\Projects\MO_P0040-01\Drawings\MO_P0040-01_SHEET 1 OF 9.dwg
 Author: Charles Thomas



**Southern Sandoval
County
Arroyo Flood Control
Authority**

1041 Commercial Dr. S.E.
Rio Rancho, New Mexico 87124
505-892-RAIN (7246)
505-892-7241 (Fax)
www.sscafca.com



HARVEY JONES CHANNEL
RIVER OUTFALL

TYPICAL SECTIONS

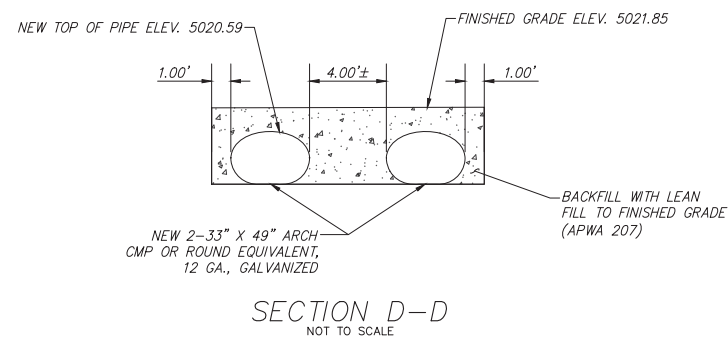
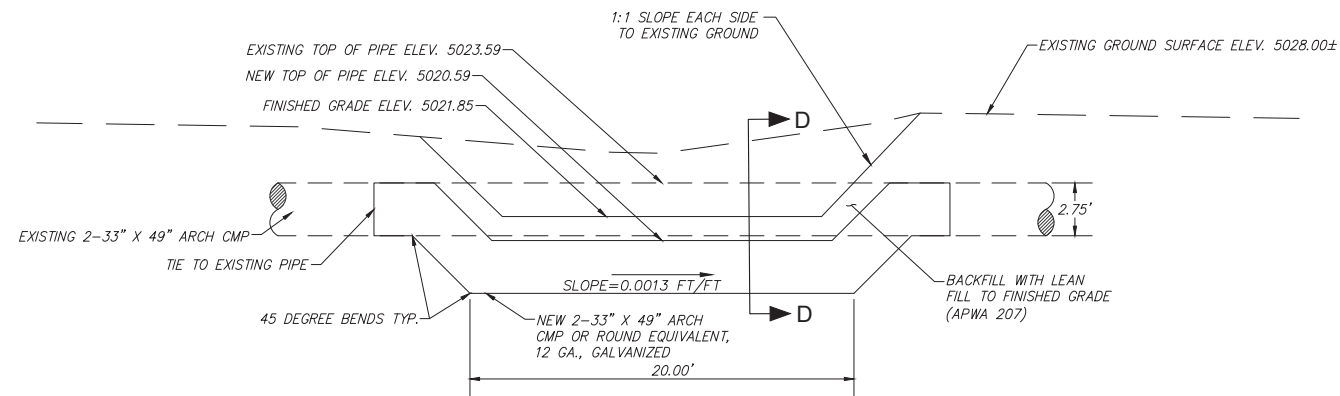
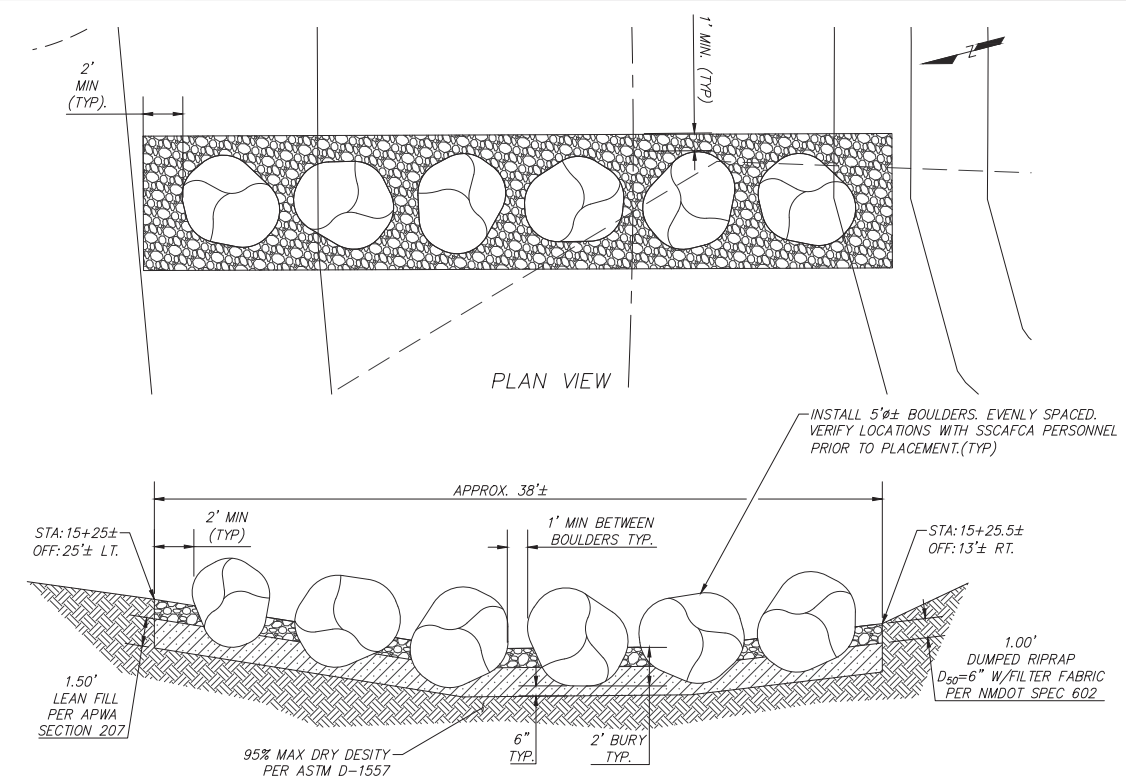
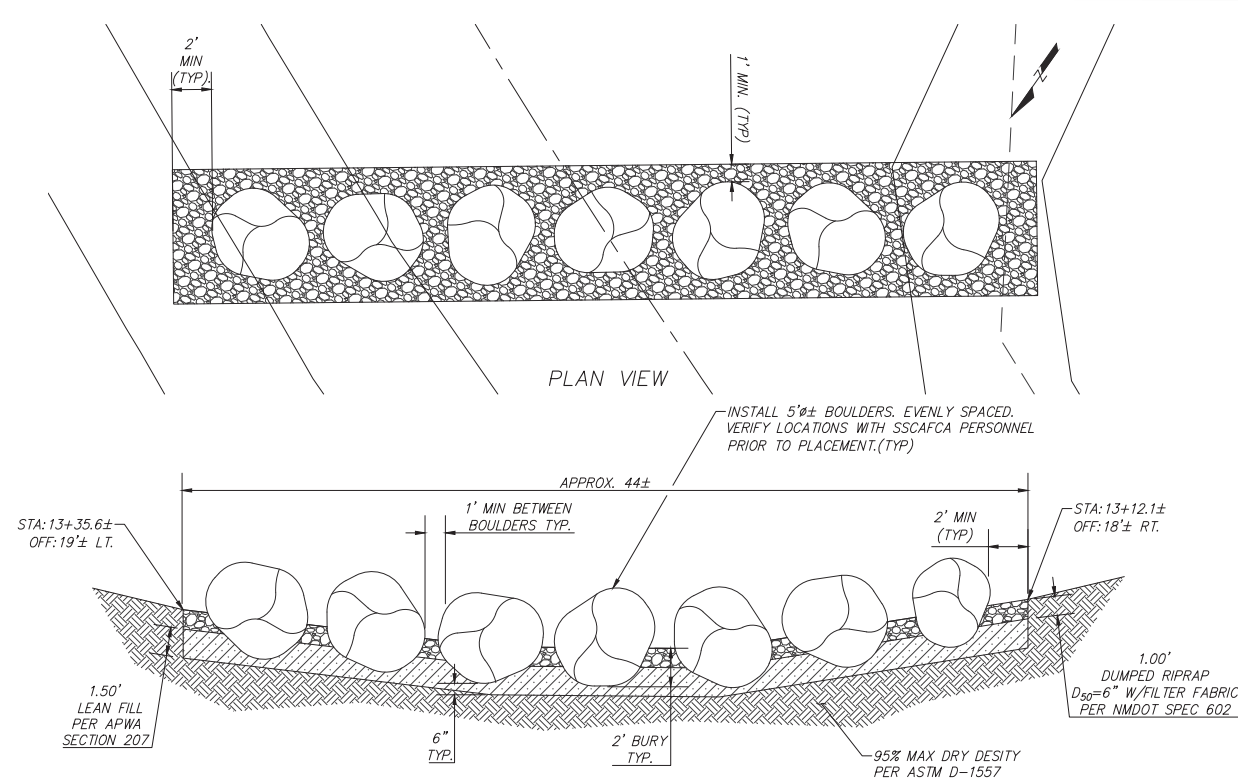

REVISIONS & CHANGE NOTICES

MARK	DESCRIPTION	DATE

PROJECT NO: MO_P0040-01
DESIGNED BY: DG
DRAWN BY: KLF
CHECKED BY: AE
DATE: 9/3/2021

Notice of Extended Payment Provision
This contract allows the owner to make payment within 45 days after submission of an undisputed request for payment.

P:\000\September 3, 2021 9:00:14 AM-KLF\DWG\SSCAFCA\PROJECT FILES\MONTANAS\MO_P0040-01\AUTOCAD\SOURCE DRAWINGS\SURFACES\MO_P0040-01_C-SURF.rvt
 © SSCAFCA PROJECT FILES\MONTANAS\MO_P0040-01